



Adipocyte Lipolysis Assay Kit for 3T3-L1 Cells: Glycerol Detection

Cat# LIP-1-L1; LIP-1-NCL1, LIP-1-L1-F, LIP-1-NCL1DIF

INSTRUCTION MANUAL ZBM0008.05

STORAGE CONDITIONS

- 96-well plate cultured 3T3-L1 preadipocytes (LIP-1-L1 only): 37°C incubator
- Cryopreserved 3T3-L1 preadipocytes (LIP-1-L1-F only): liquid nitrogen
 - This product is shipped on dry ice. Remove and store in liquid nitrogen storage **immediately** upon arrival.
- Glycerol Reagent A & Buffers: 4°C **Use reconstituted Glycerol Reagent A within 7 days!**
- Glycerol Standard & Controls: -20°C
- Media: 4°C or -20°C [see label for details]

All Zen-Bio Inc products are for research use only. Not approved for human or veterinary use or for use in diagnostic or clinical procedures.

LIMITED PRODUCT WARRANTY

This warranty limits our liability to replacement of this product. No other warranties of any kind, expressed or implied, including without limitation, implied warranties of merchantability or fitness for a particular purpose, are provided by Zen-Bio, Inc. Zen-Bio, Inc. shall have no liability for any direct, indirect, consequential, or incidental damages arising out of the use, the results of use, or the inability to use this product.

ORDERING INFORMATION AND TECHNICAL SERVICES

- Zen-Bio, Inc.
- 3200 East North Carolina Highway 54 Suite 100
- PO Box 13888
- Research Triangle Park, NC 27709
- Telephone (919) 547-0692
- Facsimile (FAX) (919) 547-0693
- Toll Free 1-866-ADIPOSE (866)-234-7673
- Electronic mail (e-mail) information@zen-bio.com
- World Wide Web <http://www.zen-bio.com>

INTRODUCTION

Lipolysis plays a central role in the regulation of energy balance. Lipolysis is the process in which triglycerides (TG) are hydrolyzed into glycerol and free fatty acids. This process releases free fatty acids (FFA) into the bloodstream where they may be either re-esterified by the adipocyte or travel to other tissues and exert other effects throughout the body. Elevated adipocyte lipolysis has been observed in obese and diabetic individuals (Arner 1996). Excessive free fatty acid production is believed to contribute to insulin resistance in skeletal muscle that is observed in obesity. Hormone sensitive lipase is the rate-limiting enzyme catalyzing triglyceride breakdown. Perilipins, one of the PAT (perilipins, adipophilin, TIP47 proteins) family of lipid-associated proteins, are implicated in adipocyte lipolysis by mediating the interaction of HSL with the triacylglycerol molecule (Brasaemle *et al.* 2004; reviewed in, Tansey *et al.* 2004.) The presence of these proteins corresponds to lipolytic stimulation in cultured adipocytes (Braemle *et al.* 2004).

The sympathetic nervous system also plays a key role in the regulation of lipid mobilization. The main lipolytic pathway involves beta-agonists (β -agonists), which activate β -adrenergic receptors via the intracellular G_s proteins in adipocytes. This leads to the activation of adenylate cyclase (AC), which then increases cyclic AMP (cAMP) levels. Elevated cAMP acts as a second messenger to activate hormone sensitive lipase (HSL). HSL, the rate-limiting enzyme regulating adipocyte lipolysis, then catalyzes the hydrolysis of triglycerides and results in the release of glycerol and FFA (increased lipolysis). Phosphodiesterases (PDE) are enzymes that hydrolyze cAMP to 5'-AMP (5 prime adenosine monophosphate). This action results in a decrease in lipolysis. PDE inhibitors increase intracellular cAMP levels. 3-isobutyl-1-methylxanthine (IBMX), a non-specific inhibitor of cAMP phosphodiesterases (PDE), is used as the positive control if your test compounds are suspected PDE inhibitors. Isoproterenol, a non-specific β -adrenergic agonist is used as the positive control if your test compounds affect lipolysis via β -adrenergic receptors (Robidoux *et al.* 2004).

This lipolysis assay kit provides the tool to study chemical compounds that may influence lipolysis in cultured adipocytes.

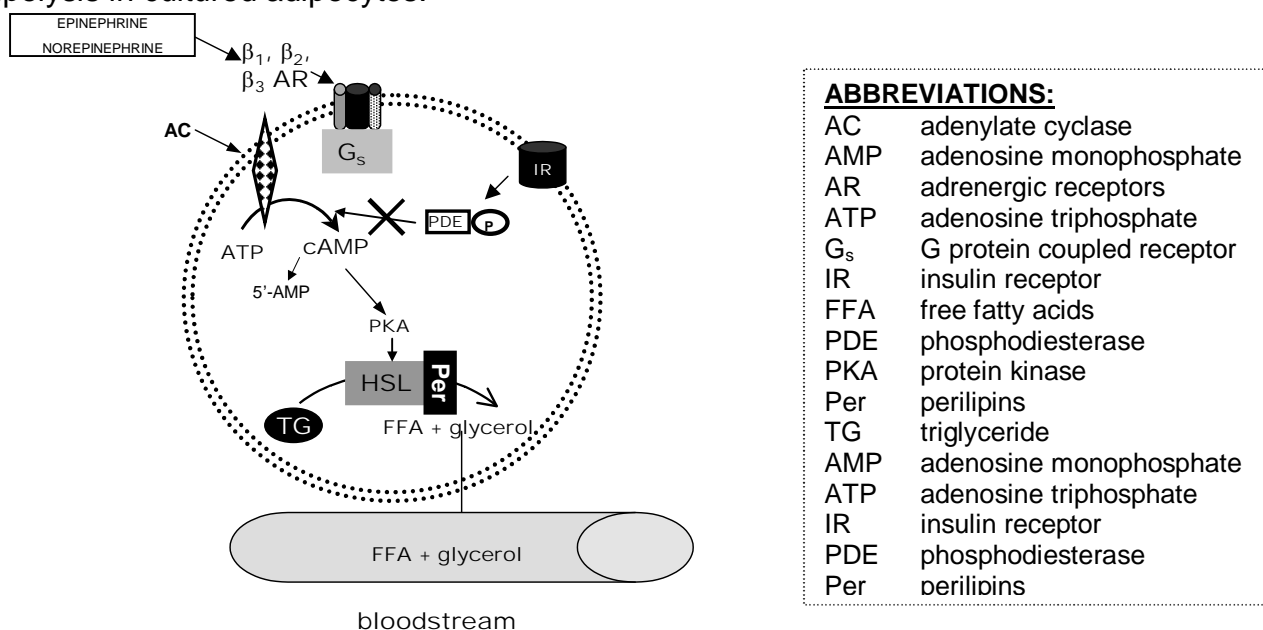
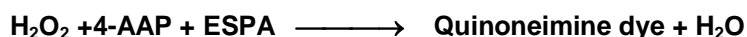
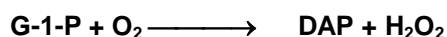

Figure 1. Overview of adipocyte lipolysis

PRINCIPLE OF THE ASSAY

Lipolytic activity is assessed by the measurement of glycerol released into the medium from triglyceride breakdown. Glycerol released to the medium is phosphorylated by adenosine triphosphate (ATP) forming glycerol-1-phosphate (G-1-P) and adenosine-5'-diphosphate (ADP) in the reaction catalyzed by glycerol kinase. G-1-P is then oxidized by glycerol phosphate oxidase to dihydroxyacetone phosphate (DAP) and hydrogen peroxide (H₂O₂). A quinoneimine dye is produced by the peroxidase catalyzed coupling of 4-aminoantipyrine (4-AAP) and sodium N-ethyl-N-(3-sulfopropyl)m-anisidine (ESPA) with H₂O₂, which shows an absorbance maximum at 540nm. The increase in absorbance at 540nm is directly proportional to glycerol concentration of the sample.



ITEMS INCLUDED IN THE KIT

ITEM	DESCRIPTION	UNIT	QTY	STORAGE
Plate A	96 well plate 3T3-L1 preadipocytes, subconfluent (LIP-1-L1 ONLY)	PLATE	1	37°C
	Cryopreserved 3T3-L1 preadipocytes, 500,000 cells, Pass 8	VIAL	1	Liquid N ₂
Assay Plates, blank	96-well assay plate, blank (for samples + standards)	PLATE	2	-----
Preadipocyte Medium (cat# PM-1-L1)	3T3-L1 Preadipocyte Medium 50ml (LIP-1-L1, LIP-1-L1-F, LIP-1-NCL1DIF ONLY)	BOTTLE	1	4°C
Differentiation Medium (cat# DM-2-L1)	3T3-L1 Adipocyte Differentiation); 15ml (LIP-1-L1, LIP-1-L1-F, LIP-1-NCL1DIF ONLY)	BOTTLE	1	4°C
Adipocyte Medium (cat# AM-1-L1)	3T3-L1 Adipocyte Maintenance; 100ml (LIP-1-L1, LIP-1-L1-F, LIP-1-NCL1DIF ONLY)	BOTTLE	1	4°C
Assay Buffer	100 ml	BOTTLE	1	4°C
Wash Buffer	50 ml	BOTTLE	1	4°C
Vehicle (green cap)	0.1% DMSO in Assay Buffer READY TO USE	1 ml / VIAL	1	-20°C
Positive Control (blue cap)	Isoproterenol, 10 mM in DMSO. <u>Dilute to 1 µM in Assay Buffer before use!</u> (i.e. 1 µl in 10 ml Assay Buffer)	10 µl / VIAL	1	-20°C
Alternate Positive Control (red cap)	3-Isobutyl-1-methylxanthine (IBMX), 100 mM in DMSO <u>Dilute to 100 µM in Assay Buffer before use!</u> (i.e. 1 µl in 1 ml Assay Buffer)	10 µl / VIAL	1	-20°C
Glycerol Reagent A (cat# RGTA-10)	Reconstitute with 11.0 ml deionized water prior to use. Use within 7 days!	BOTTLE	1	4°C
Tray	For multi-channel pipettors, clear polyvinyl	EACH	2	-----
Glycerol standard (cat# LIP-GLYSTAN)	Glycerol @ 1mM [Reconstitute with 400 µl Wash Buffer to make the 200 µM glycerol standard; see page 6 for recommended dilution scheme]	100 µl / VIAL	1	-20°C

Other equipment/reagents required but not provided with the kit:

- Multi-channel pipet , single channel pipet and pipet tips
- Sterile trays for multi-channel pipetters during differentiation of cells
- Plate reader with a filter of 540 nm
- Incubator at 37°C
- Large gauge needle
- Option – Step 5 of Assay Procedure: 96 well plate, blank
- Tubes for diluting glycerol standards

NOTE:

THIS KIT IS DESIGNED FOR THE ASSAY OF A 96 WELL PLATE (100 ASSAY POINTS). IF YOU WISH TO TEST ANOTHER PLATE FORMAT, PLEASE CONTACT ZEN-BIO TO PURCHASE ADDITIONAL REAGENTS TO COMPLETE YOUR STUDY.

ASSAY PROCEDURE

A. DIFFERENTIATION PROCEDURE

1. Preparing 3T3-L1 preadipocytes:

1.1. Cat# LIP-1-L1:

- 1.1.1. Preadipocytes are plated sub-confluent in 3T3-L1 Preadipocyte Medium (cat# PM-1-L1) and shipped the next day via overnight delivery. Check the seal for each plate. Call Zen-Bio if there is any problem with the shipment. Place the package into a sterile environment. THIS IS VERY IMPORTANT SINCE BREAKING THE VACUUM SEAL MAY POTENTIALLY INTRODUCE CONTAMINATION INTO THE PLATE. Use scissors to snip open the bag at any end to release the vacuum seal.
- 1.1.2. In a sterile environment, remove the plate from the bag, taking care to not disturb the cover top from the plate. Open the lid and remove the white liner using sterile forceps or a hemostat and discard. Carefully remove the clear adhesive seal by grabbing the edge with sterile forceps or hemostat and lifting the film slowly towards the other end. Discard adhesive film in appropriate biohazard waste container.
- 1.1.3. Remove 100-150µl per well of the excess medium added to each well for shipping should prior to incubation in a CO₂ incubator. Replace lid on plate.
- 1.1.4. Incubate cells until they are 100% confluent (in about 4-5 days). Cells will need to be fed every other day with PM-1-L1 during this time. See Table 1 for feeding volumes. See Step 2 for further differentiation instructions.

1.2. Cat# LIP-1-L1-F:

- 1.2.1. Store cells in liquid nitrogen until ready for use. Remove cells from liquid nitrogen and place immediately into a 37°C water bath with agitation. Be careful not to submerge the cap of the vial into water. Do not leave the vials in water bath after most of the content has thawed. Rinse the vials with 70% ethanol before taking them to the culture hood.
- 1.2.2. Upon thawing, add the cells to a sterile conical bottom centrifuge tube, containing 10 ml of 3T3-L1 Preadipocyte Medium (PM-1-L1). Centrifuge at 280 x g, 20°C, 5 minutes.
- 1.2.3. Aspirate the medium and resuspend cells in a volume of PM-1-L1 appropriate for counting the cells. Count using a hemacytometer. Place approximately 5,000-10,000 cells/cm² in 150µl per well volume in a 96-well tissue culture treated cultureware using 3T3-L1 Preadipocyte Medium (PM-1-L1).

Cells will need to be fed every other day with PM-1-L1 during this time. See Table 1 for feeding volumes. Maintain cells until they are 100% confluent (in about 4-5 days) in a humidified incubator, 37°C, with 5-10% CO₂.

2. Differentiation procedure:
3. Once the cells are 100% confluent, incubate an additional 48 hours before initiating differentiation.
4. Two days after the cells have been confluent, remove the Preadipocyte Medium (cat# PM-1-L1) and replace with an appropriate volume 3T3-L1 Differentiation Medium (cat# DM-2-L1; see table 1 below for recommended volumes). Incubate for 3 days.
5. Remove the 3T3-L1 Differentiation Medium and replace with 3T3-L1 Adipocyte Maintenance Medium. Incubate for 2-3 days.
6. Feed cells every 2-3 days using 3T3-L1 Adipocyte Maintenance Medium until ready for assay. 3T3-L1 adipocytes are suitable for most assays 7-14 days post differentiation (see Table 1 and 3T3-L1 Growth and Differentiation Feeding Schedule)

Table 1. Feeding Volumes

Format	Change PM-1-L1 to PM-1-L1		Change PM-1-L1 to DM-2-L1		Change DM-2-L1 to AM-1-L1		Change AM-1-L1 to AM-1-L1	
	OUT	IN	OUT	IN	OUT	IN	OUT	IN
96 well plate	90µl/well	90µl/well	150µl/well	150 µl / well	90 µl /well	120µl /well	90 µl /well	120µl /well
48 well plate	300 µl /well	300 µl /well	500µl /well	500 µl /well	300 µl /well	400 µl /well	300 µl /well	400 µl /well
24 well plate	0.6 ml/well	0.6 ml/well	1.0 ml/well	1.0 ml/well	0.6 ml/well	0.8 ml/well	0.6 ml/well	0.8 ml/well
12 well plate	1.2 ml/well	1.2 ml/well	2.0 ml/well	2.0 ml/well	1.2 ml/well	1.6 ml/well	1.2 ml/well	1.6 ml/well
6 well plate	1.8 ml/well	1.8 ml/well	3.0 ml/well	3.0 ml/well	1.8 ml/well	2.4 ml/well	1.8 ml/well	2.4 ml/well
T-75 flask	12 ml/flask	12 ml/flask	20 ml/flask	20 ml/flask	12 ml/flask	16 ml/flask	12 ml/flask	16 ml/flask
T-25 flask	4.2 ml/flask	4.2 ml/flask	7 ml/flask	7 ml/flask	4.2 ml/flask	5.6 ml/flask	4.2 ml/flask	5.6 ml/flask

3T3-L1 Growth and Differentiation Feeding Schedule

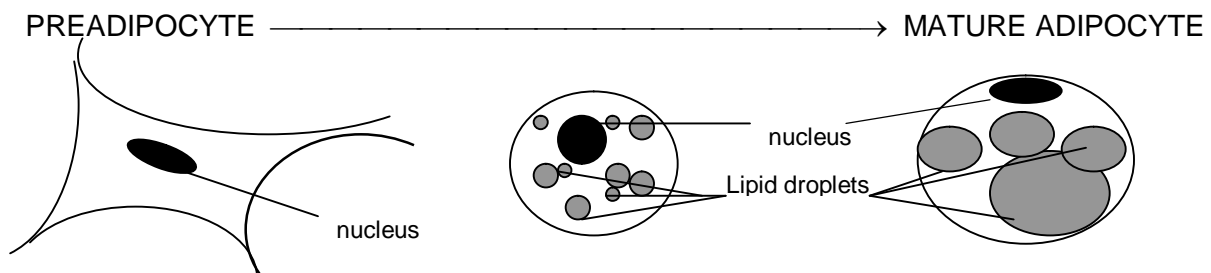
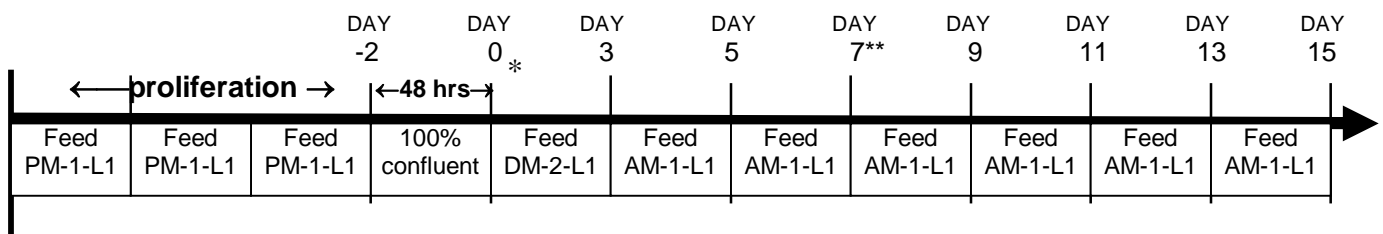

* Once the cells are 100% confluent, incubate an additional 48 hours before initiating differentiation.

** 3T3-L1 adipocytes are suitable for most assays 7-14 days post differentiation

B. LIPOLYSIS PROCEDURE

1. Make your stock solution using whatever vehicle is appropriate for your test compounds. Dilute your stock solutions to their final concentration in Assay Buffer (100 ml is available). NOTE: if desired, maintain a constant concentration of solvent by preparing all compound dilutions in the highest concentration of that solvent. Dilute your controls in assay buffer. Prepare all vehicles as appropriate for your compounds, 0.1% DMSO has been included as the vehicle for the positive controls. Include the Assay Buffer alone as a vehicle control. PLEASE NOTE: ZEN-BIO DOES NOT RECOMMEND THE USE OF SOLVENTS AT CONCENTRATIONS ABOVE 1%.
2. Remove 120 μ l medium from each well. Gently add 200 μ l Wash Buffer to all wells. Remove 200 μ l of the media and Wash Buffer from each well and replace with another 200 μ l Wash Buffer.
3. Remove all the media and Wash Buffer from the cells in triplicate wells. Treat the cells with 150 μ l of the test compounds resuspended in Assay Buffer three (3) wells at a time. Treat with the diluted IBMX and Isoproterenol as positive controls. Use the Assay Buffer alone as one of the vehicle controls. Please be sure to include both the vehicle provided in the kit and your vehicle (if your test compounds are not dissolved in DMSO). The assay should be performed in triplicate.
4. OPTION: to determine if the compound alone reacts with the Glycerol Reagent A, prepare a fresh plate (not included in kit) containing 100 μ l of the compound. This plate can be incubated at 37°C with the treated cells. When performing the assay, add 100 μ l of Glycerol Reagent A following the instructions in Steps 9 and 10.
5. Incubate the plates at 37°C in a humidified incubator for 3 hours (for time course experiments the longest time point is usually 24 hours).
6. One hour prior to the assay, prepare the glycerol standards as follows:

Briefly spin down the contents of the glycerol standard tube before reconstitution. Pipette 400 μ l of Wash Buffer into the 1 mM glycerol standard tube provided and mix well by vortexing. This produces a diluted stock glycerol standard of 200 μ M. Pipette 250 μ l of wash buffer into 6 tubes (not provided). Using the newly diluted stock glycerol solution, prepare a dilution series as depicted below. Mix each new dilution thoroughly before proceeding to the next. The 200 μ M stock dilution serves as the highest standard, and the wash buffer serves as the zero standard.

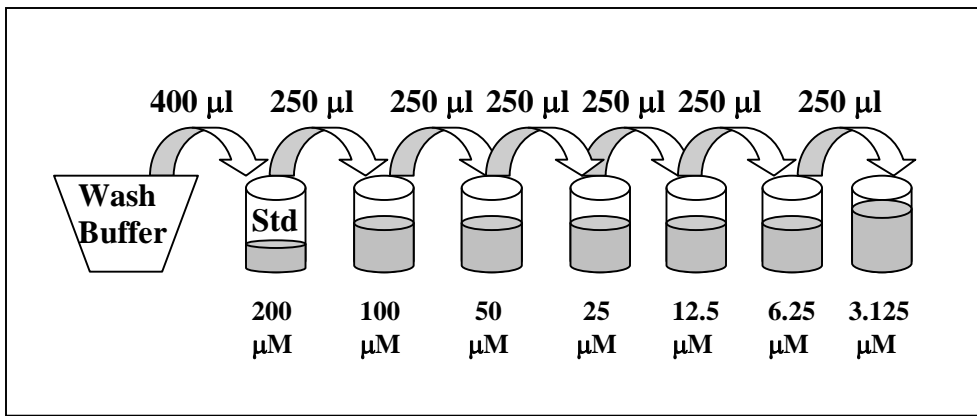

Note: The above dilution series generates enough volume to perform the standard curve in duplicate. If you wish to perform the standard curve in duplicate, please note that eight fewer data points can be assayed with this kit.

7. Also at this time prepare the Glycerol Reagent A by adding 11.0 ml room temperature deionized water per bottle and gently invert. DO NOT VORTEX! Use a pipet to ensure that the powder is completely dissolved. Store at room temperature. If using a Reagent A solution previously prepared and stored at 2-8°C, also bring to room temperature. Make sure there is enough Reagent A from one solution to treat all the points in the assay. It may be necessary to combine solutions. Store in a light protected bottle. Reconstituted Glycerol Reagent A is stable for 7 days refrigerated (2-8°C); store any remaining solution refrigerated (2-8°C).
8. At the end of the incubation, 100 µl of the conditioned media is removed and transferred to the corresponding well of Plate B. [This is most easily accomplished using a multi-channel pipet.] Add 100 µl of each glycerol standard to any remaining empty wells in Plate B or use Plate C for the standards.
9. Add the reconstituted Glycerol Reagent A solution to one of the disposable trays provided in the kit. Add 100 µl of Reagent A to each well of Plate B and Plate C (if used). Gently, pipet up and down once to mix. Pop the bubbles using a large gauge needle or a clean pipet tip. The plate is then incubated at 25°C (room temperature) for 15 minutes.
10. The optical density of each well is then measured at 540 nm.

GLYCEROL STANDARD CURVE

Generate standard curve: see example below

[DO NOT use this standard curve to generate your data. This is an example.]

Subtract the OD value of the 0µM standard from all OD values including the standard curve.

µM glycerol	OD	OD	OD-blank	OD-blank	Avg OD-blank
0	0.044	0.041			0.043
3.125	0.054	0.053	0.012	0.011	0.011
6.25	0.062	0.063	0.020	0.021	0.020
12.5	0.083	0.084	0.041	0.042	0.041
25	0.126	0.125	0.084	0.083	0.083
50	0.205	0.208	0.163	0.166	0.164
100	0.372	0.374	0.330	0.332	0.331
200	0.698	0.697	0.656	0.655	0.655

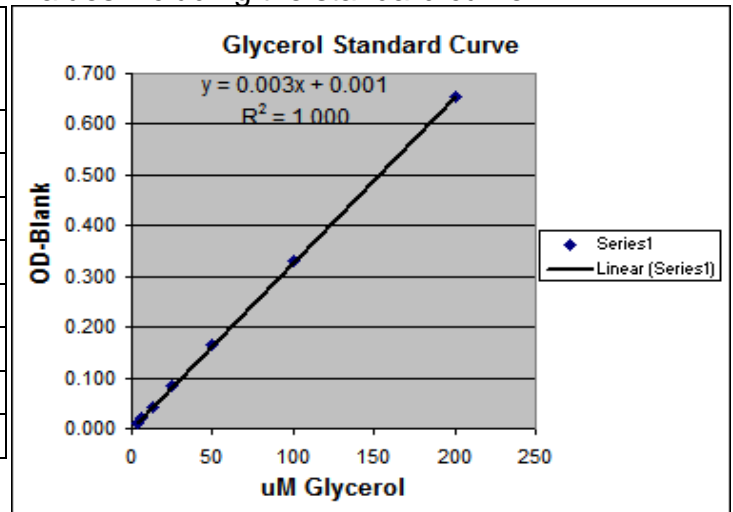

Slope	0.003
Intercept	0.001
R2	1.000

y = observed O.D. minus the blank

x = concentration of glycerol in µM

To calculate x for each y , (i.e. to change the observed O.D. into glycerol concentration) use the following equation:

$y = (\text{slope}) \times (x) + \text{intercept}$

$y = mx + b$ so $x = (y - b) / m$

$x = (y - 0.001) / 0.003$ where 0.003 = slope of the line and 0.001 = y intercept. Be careful to enter the proper sign for the y intercept value as it may be a negative number.

Any OD values greater than the highest standard (200 µM) should be suspect. The compound should be re-assayed using a lower dose of the compound at treatment OR a dilute solution of the conditioned medium at the time of the assay.

The R^2 value should be equal or greater than 0.98 for the standard curve to be valid. Any R^2 values below 0.98, must have the standard curve run again.

Data are expressed as µM glycerol released.

OPTION: express data as Fold induction over appropriate vehicle

$$\text{Fold induction} = \frac{\mu\text{M glycerol SAMPLE}}{\mu\text{M glycerol VEHICLE}}$$

TROUBLESHOOTING

Problem	Suggestions
High background or the glycerol reagent A turns purple before the assay begins.	<ul style="list-style-type: none">• Use clean tray and tips• Change pipet tips frequently• Use Glycerol Reagent A before the expiration date
No response to either positive control	<ul style="list-style-type: none">• Visually observe adequate differentiation of the cultured adipocytes prior to assay.
Edge effects	<ul style="list-style-type: none">• Ensure a saturated humidity in the incubator to prevent evaporation from the outside wells
Inconsistent OD reading	<ul style="list-style-type: none">• The Assay Buffer contains bovine serum albumin (BSA). Be careful when pipetting to avoid bubbles. If bubbles persist, burst the bubbles using a large gauge needle and read the plate again.

FREQUENTLY ASKED QUESTIONS

- 1. I want to perform a lipolysis time course experiment. How many time points can I complete?** We do not recommend performing more than 2 time points per assay. For time course experiments, add 250 μ l assay medium with treatments per well. Remove 100 μ l for each time point.
- 2. I have more samples plus standards to run than can fit on 1 96 well plate. Can I compare data obtained from multiple plates?** The lipolysis kit is designed for the assay of a single plate. You may purchase 2 or more kits of the same lot number. You may then use one plate that includes the blank, vehicle(s), and positive and negative controls. Additional plates may then be used for the assay of the remainder of your samples. In order to obtain comparable data, all plates must be assayed on the same day using kits from the same lot number. Plate C is provided for the assay of glycerol standards.
- 3. I do not have time to perform the assay. Can I freeze the conditioned media in PLATE B? How long can I store the samples before I complete the assay?** Yes. The conditioned media in PLATE B can be immediately stored at -80°C for a maximum of 7 days. Bring the conditioned media in PLATE B to room temperature BEFORE adding the Glycerol Reagent A and completing the assay.
- 4. Can I buy the reagents separately?** The Glycerol Standard, cat# LIP-GLYSTAN and Glycerol Reagent A, cat# RGTA-10 are sold separately. Assay Buffer is not sold separately.
- 5. I need to know the concentration of the BSA in the Assay Buffer?** ZenBio, Inc does not provide the concentrations of the components of our media and buffers. If knowledge of the BSA concentration is critical to your experiment, you may order Assay Buffer WITHOUT BSA for no additional charge. Please note it on your order.

APPENDIX A: PLATE LAYOUT

H	G	F	E	D	C	B	A	
								1
								2
								3
								4
								5
								6
								7
								8
								9
								10
								11
								12

APPENDIX B: PROCEDURE FLOWCHART

ON DAY OF ASSAY

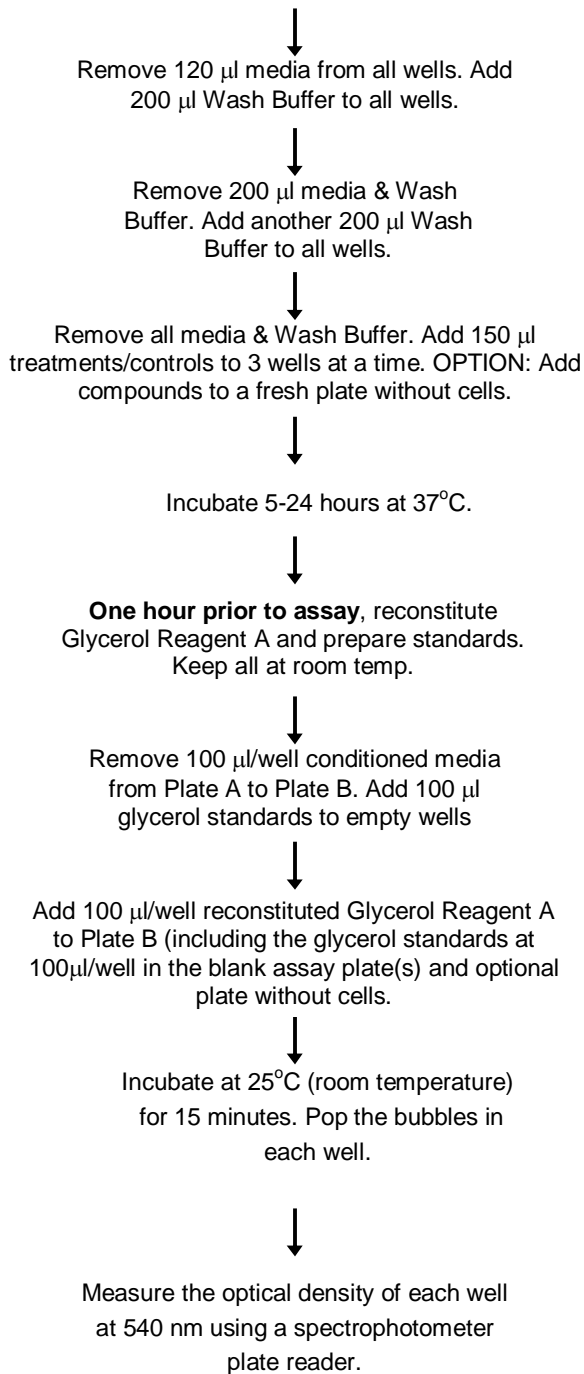
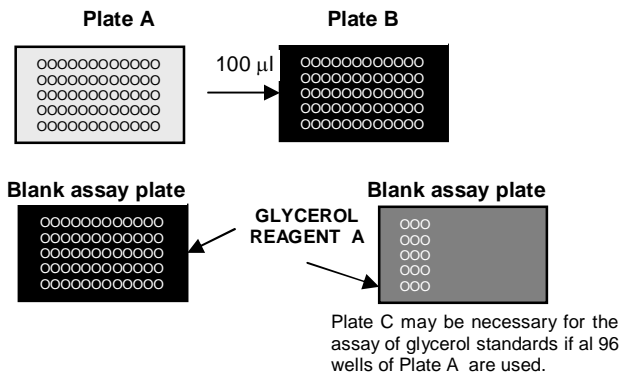
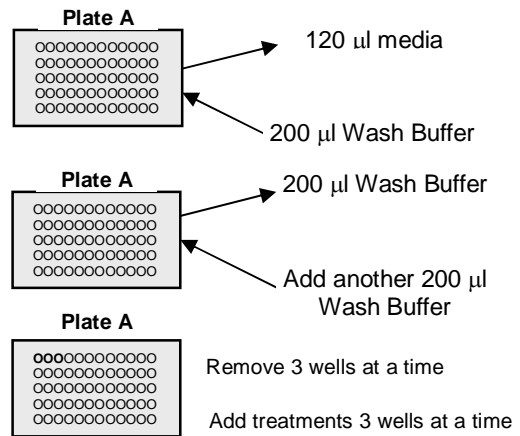

Plate A = plate of mature 3T3-L1 adipocytes



REFERENCES

1. Arner P (1996) *Diabetes Rev* 4(4):450-463.
2. Botion LM & Green A. *Diabetes* (1999) 48:1691-1697
3. Brasaemle DL, Dolios G, Shapiro L, Wang R. (2004) *J Biol Chem* 279(45): 46835-42.
4. Cooper DMF, Schlegel W, Lin MC, Rodbell M. (1979) *J Biol Chem* 254(18):8927-8931.
5. Dyck DJ *Can J Appl Physiol* (2000) 25(6):495-523.
6. Kordik CP & Reitz AB. *J Medicinal Chem* (1999) 42(2):181-201.
7. Rieusset J, Chambrier C, Bouzakri K, Dussere E, Auwerx J, Riou J-P, Laville M, Vidal H. *Diabetologia* (2001) 44:544-554.
8. Robidoux J, Martin TL, Collins S. (2004) *Ann Rev Chem* 253: 7570-7578.
9. Scriba D, Aprath-Husmann I, Blum WF, Hauner H. *Eur J Endocrinol* (2000) 143:439-445
10. Snyder PB *Emerging Therapeutic Targets* (1999) 3(4): 587-599.
10. Tansey JT, Sztalryd C, Hlavin EM, Kimmel AR, Londos C. (2004) *IUBMB Life* 56(7): 379-85.