



# Cultured Human Adipocyte Lipolysis Assay Kit-500 point assay kit 96-well Format Cat# LIP-1-RB

**INSTRUCTION MANUAL    ZBM0027.04**

## **STORAGE CONDITIONS**

All orders are delivered via Federal Express Priority courier at ambient temperature.  
All orders must be processed immediately upon arrival.

### **Glycerol Reagent A & Buffers:**

Store at 4°C.

### **Glycerol Standards & Controls:**

Store at -20°C

***ALL ZEN-BIO INC PRODUCTS ARE FOR RESEARCH USE ONLY. NOT APPROVED FOR HUMAN OR VETERINARY USE OR FOR USE IN DIAGNOSTIC OR CLINICAL PROCEDURES.***

## **LIMITED PRODUCT WARRANTY**

This warranty limits our liability to replacement of this product. No other warranties of any kind, expressed or implied, including without limitation, implied warranties of merchantability or fitness for a particular purpose, are provided by Zen-Bio, Inc. Zen-Bio, Inc. shall have no liability for any direct, indirect, consequential, or incidental damages arising out of the use, the results of use, or the inability to use this product.

## **ORDERING INFORMATION AND TECHNICAL SERVICES**

- **Zen-Bio, Inc.**
- **3200 Chapel Hill-Nelson Blvd., Suite 104**
- **PO Box 13888**
- **Research Triangle Park, NC 27709**
- **Telephone** (919) 547-0692
- **Facsimile (FAX)** (919) 547-0693
- **Toll Free** 1-866-ADIPOSE (866)-234-7673
- **Electronic mail (e-mail)** [information@zen-bio.com](mailto:information@zen-bio.com)
- **World Wide Web** <http://www.zenbio.com>

# INTRODUCTION

---

Lipolysis plays a central role in the regulation of energy balance. Lipolysis is the process in which triglycerides (TG) are hydrolyzed into glycerol and free fatty acids. This process releases free fatty acids (FFA) into the bloodstream where they may be either re-esterified by the adipocyte or travel to other tissues and exert other effects throughout the body. Elevated adipocyte lipolysis has been observed in obese and diabetic individuals (Arner 1996). Excessive free fatty acid production is believed to contribute to insulin resistance in skeletal muscle that is observed in obesity. Hormone sensitive lipase is the rate-limiting enzyme catalyzing triglyceride breakdown. Perilipins, one of the PAT (perilipins, adipophilin, TIP47 proteins) family of lipid-associated proteins, are implicated in adipocyte lipolysis by mediating the interaction of HSL with the triacylglycerol molecule (Brasaemle *et al.* 2004; reviewed in, Tansey *et al.* 2004.) The presence of these proteins corresponds to lipolytic stimulation in cultured adipocytes (Braemle *et al.* 2004).

The sympathetic nervous system also plays a key role in the regulation of lipid mobilization. The main lipolytic pathway involves beta-agonists ( $\beta$ -agonists), which activate  $\beta$ -adrenergic receptors via the intracellular  $G_s$  proteins in adipocytes. This leads to the activation of adenylate cyclase (AC), which then increases cyclic AMP (cAMP) levels. Elevated cAMP acts as a second messenger to activate hormone sensitive lipase (HSL). HSL, the rate-limiting enzyme regulating adipocyte lipolysis, then catalyzes the hydrolysis of triglycerides and results in the release of glycerol and FFA (increased lipolysis). Phosphodiesterases (PDE) are enzymes that hydrolyze cAMP to 5'-AMP (5 prime adenosine monophosphate). This action results in a decrease in lipolysis. PDE inhibitors increase intracellular cAMP levels. 3-isobutyl-1-methylxanthine (IBMX), a non-specific inhibitor of cAMP phosphodiesterases (PDE), is used as the positive control if your test compounds are suspected PDE inhibitors. Isoproterenol, a non-specific  $\beta$ -adrenergic agonist is used as the positive control if your test compounds affect lipolysis via  $\beta$ -adrenergic receptors (Robidoux *et al.* 2004).

This lipolysis assay kit provides the tool to study chemical compounds that may influence lipolysis in cultured human adipocytes. This kit detects lipolysis as the amount of glycerol released from mammalian cells in a 96-well format. This kit contains sufficient volume of reagents to assay 500 data points (~5 96 well plates).

## Figure 1. Overview of adipocyte lipolysis

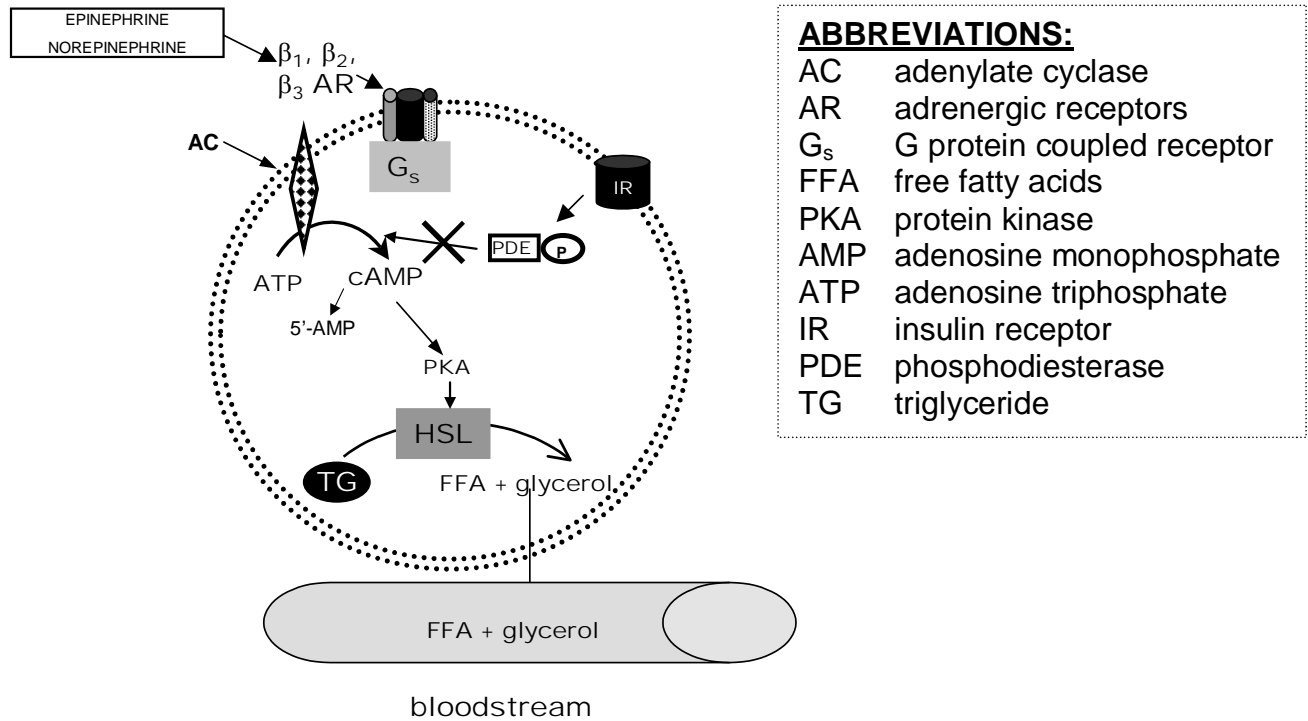

### PRINCIPLE OF THE ASSAY

Glycerol released to the medium is phosphorylated by adenosine triphosphate (ATP) forming glycerol-1-phosphate (G-1-P) and adenosine-5'-diphosphate (ADP) in the reaction catalyzed by glycerol kinase. G-1-P is then oxidized by glycerol phosphate oxidase to dihydroxyacetone phosphate (DAP) and hydrogen peroxide (H<sub>2</sub>O<sub>2</sub>). A quinoneimine dye is produced by the peroxidase catalyzed coupling of 4-aminoantipyrine (4-AAP) and sodium N-ethyl-N-(3-sulfo-propyl)m-anisidine (ESPA) with H<sub>2</sub>O<sub>2</sub>, which shows an absorbance maximum at 540nm. The increase in absorbance at 540nm is directly proportional to glycerol concentration of the sample.

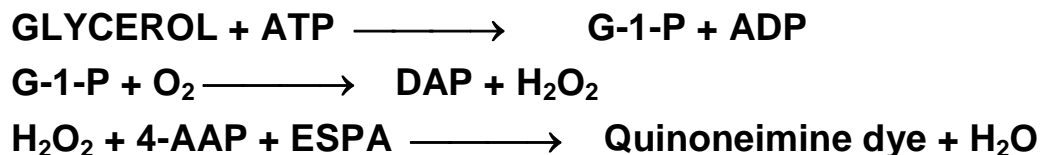

## ITEMS INCLUDED IN THE KIT

---

ITEM	DESCRIPTION	UNIT	QTY	STORAGE
<b>LIP-1 Assay Buffer</b>	500 ml	BOTTLE	1	4°C
<b>Wash Buffer</b>	250 ml	BOTTLE	1	4°C
<b>Glycerol Reagent A</b> (cat# RGTA-40)	40-ml- Reconstitute with 40 ml deionized water prior to use.	40ML BOTTLE	1	4°C
<b>Glycerol Reagent A</b> (cat# RGTA-10)	11-ml- Reconstitute with 11 ml deionized water prior to use.	11ML BOTTLE	1	4°C
<b>Glycerol standard</b> (cat# LIP-GLYSTAN) Orange cap	Glycerol @ 1mM [Reconstitute with 400 µl Wash Buffer to make the 200 µM glycerol standard; see page 6 for recommended dilution scheme]	100 µl / VIAL	2	-20°C
<b>Vehicle Control</b> Green cap	0.1% DMSO in Assay Buffer	1 ml / VIAL	2	-20°C
<b>Positive control</b> Blue cap	Isoproterenol, 10 mM in DMSO. <u>Dilute to 1 µM in Assay Buffer before use!</u> (i.e. 1 µl in 10 ml Assay Buffer)	10 µl / VIAL	2	-20°C

### Other equipment/reagents required but not provided with the kit:

- Clean/disposable pipettor trays
- Blank 96 well plates
- Multi-channel Pipet , single channel pipet and pipet tips
- Plate reader with a filter of 540 nm
- Incubator at 37°C
- Large gauge needle
- Cultured human adipocytes
- Tubes for diluting glycerol standards

## ASSAY PROCEDURE

---

1. Please observe your cells under a microscope prior to performing the assay.
2. Make your stock solution using whatever vehicle is appropriate for your test compounds. Dilute your stock solutions to their final concentration in Assay Buffer (500 ml is available). NOTE: if desired, maintain a constant concentration of solvent by preparing all compound dilutions in the highest concentration of that solvent. Dilute your controls in Assay Buffer. Prepare all vehicles as appropriate for your compounds. Include the Assay Buffer alone as a vehicle control. PLEASE NOTE: ZEN-BIO DOES NOT RECOMMEND THE USE OF SOLVENTS AT CONCENTRATIONS ABOVE 1%.
3. Remove 120  $\mu$ l medium from each well. Gently add 200  $\mu$ l Wash Buffer to all wells. Remove 200  $\mu$ l of the media and Wash Buffer from each well and replace with another 200  $\mu$ l Wash Buffer.
4. Remove all the media and Wash Buffer from the cells from triplicate wells. Treat the cells with 150  $\mu$ l of the test compounds resuspended in Assay Buffer three (3) wells at a time. You can treat with isoproterenol in assay buffer as the positive control (not provided in this kit). Use the Assay Buffer alone as one of the vehicle controls. Please be sure to include your vehicle (if your test compounds are not dissolved in DMSO). The assay should be performed in triplicate.
5. OPTION: to determine if the compound alone reacts with the Glycerol Reagent A, prepare a fresh plate (not included in kit) containing 100  $\mu$ l of the compound. This plate can be incubated at 37°C with the treated cells. When performing the assay, add 100  $\mu$ l of Glycerol Reagent A following the instructions in Steps 10 and 11.
6. Incubate the plates at 37°C-humidified incubator for 3 hours (for time course experiments the longest time point is usually 24 hours).
7. **One hour prior to the assay, prepare the glycerol standards as follows:**

Briefly spin down the contents of the glycerol standard tube before reconstitution. Pipette 400  $\mu$ l of Wash Buffer into the 1 mM glycerol standard tube provided and mix well by vortexing. This produces a diluted stock glycerol standard of 200  $\mu$ M. Pipette 250  $\mu$ l of wash buffer into 6 tubes (not provided). Using the newly diluted stock glycerol solution, prepare a dilution series as depicted below. Mix each new dilution

thoroughly before proceeding to the next. The 200  $\mu\text{M}$  stock dilution serves as the highest standard, and the wash buffer serves as the zero standard.

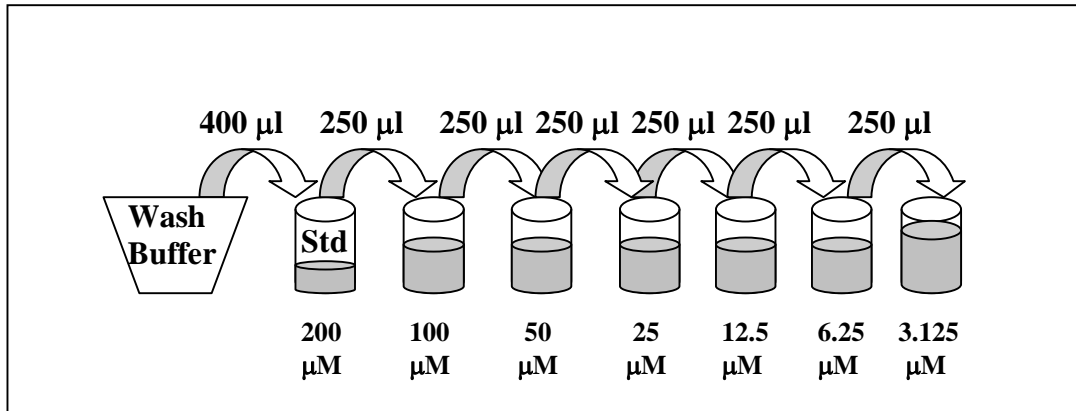

**Note:** The above dilution series generates enough volume to perform the standard curve in duplicate. If you wish to perform the standard curve in duplicate, please note that eight fewer data points can be assayed with this kit.

8. At this time prepare the Glycerol Reagent A by adding 40 ml or 11 ml room temperature deionized water per bottle following the instructions on the bottle. Gently invert bottle to mix contents. DO NOT VORTEX! Use a pipet to ensure that the powder is completely dissolved. Store in a light protected bottle. Reconstituted Glycerol Reagent A is stable for 60 days refrigerated (2-8°C); store any remaining solution refrigerated (2-8°C). You may order additional glycerol standards for the Lipolysis Kit (cat# LIP-GLYSTAN).
9. At the end of the incubation, 100  $\mu\text{l}$  of the conditioned media is removed and transferred to the corresponding well of another blank plate. [This is most easily accomplished using a multi-channel pipet.] Add 100  $\mu\text{l}$  of each glycerol standard to any remaining empty wells in one of the blank assay plates.
10. Add the reconstituted Glycerol Reagent A solution to a disposable tray (not provided). Add 100  $\mu\text{l}$  of Reagent A to each well of the assay plates containing samples. Gently, pipet up and down once to mix. Pop the bubbles using a large gauge needle or a clean pipet tip. The plate is then incubated at 25°C (room temperature) for 15 minutes.
11. The optical density of each well is then measured at 540 nm.

# GLYCEROL STANDARD CURVE

Generate standard curve: see example below

[DO NOT use this standard curve to generate your data. This is an example.]

Subtract the OD value of the 0 $\mu$ M standard from all OD values including the standard curve.

uM glycerol	OD	OD	OD-blank	OD-blank	Avg OD-blank
0	0.044	0.041			0.043
3.125	0.054	0.053	0.012	0.011	0.011
6.25	0.062	0.063	0.020	0.021	0.020
12.5	0.083	0.084	0.041	0.042	0.041
25	0.126	0.125	0.084	0.083	0.083
50	0.205	0.208	0.163	0.166	0.164
100	0.372	0.374	0.330	0.332	0.331
200	0.698	0.697	0.656	0.655	0.655

Slope	0.003
Intercept	0.001
R <sup>2</sup>	1.000

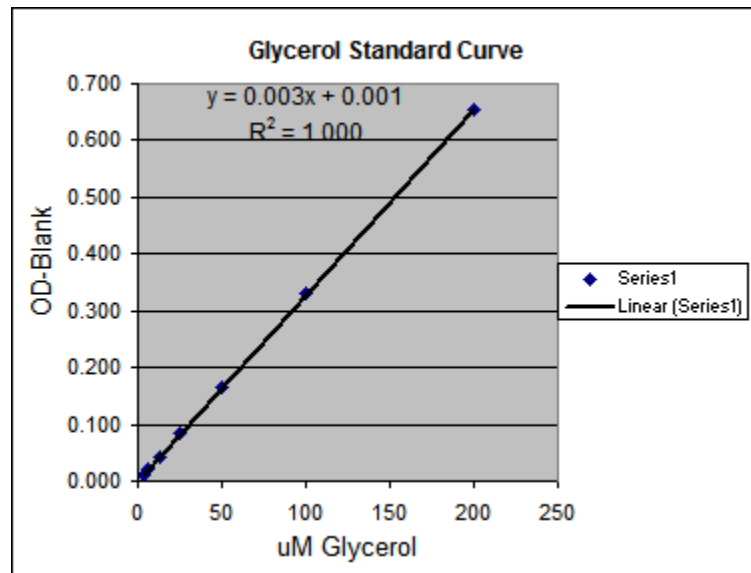

**y = observed O.D. minus the blank**

x = concentration of glycerol in  $\mu$ M

To calculate x for each y, (i.e. to change the observed O.D. into glycerol concentration) use the following equation:

$y = (\text{slope}) \times (x) + \text{intercept}$

$y = mx + b$  so  $x = (y - b) / m$

$x = (y - (0.001)) / 0.003$  where 0.003 = slope of the line and 0.001 = y intercept. Be careful to enter the proper sign for the y intercept value as it may be a negative number.

Any OD values greater than the highest standard (200  $\mu$ M)  should be suspect. The compound should be re-assayed using a lower dose of the compound at treatment OR a dilute solution of the condition medium at the time of the assay.

**The R<sup>2</sup> value should be equal or greater then 0.98 for the standard curve to be valid. Any R<sup>2</sup> values below 0.98, must have the standard curve run again.**

Data are expressed as  $\mu$ M glycerol released.

OPTION: express data as Fold induction over appropriate vehicle

$$\text{Fold induction} = \frac{\mu\text{M glycerol SAMPLE}}{\mu\text{M glycerol VEHICLE}}$$

## TROUBLESHOOTING

---

Problem	Suggestions
High background or the glycerol reagent A turns purple before the assay begins.	<ul style="list-style-type: none"><li>• Change pipet tips frequently</li><li>• Use Glycerol Reagent A before the expiration date</li></ul>
No response to positive control	<ul style="list-style-type: none"><li>• Do not add the compounds and controls too fast. The cells can float if a solution is added too fast.</li><li>• Make sure to starve the cells for 5-7 days <b>BEFORE</b> initiating treatment.</li></ul>
Edge effects	<ul style="list-style-type: none"><li>• Ensure a saturated humidity in the incubator to prevent evaporation from the outside wells</li></ul>
Inconsistent OD reading	<ul style="list-style-type: none"><li>• The Assay Buffer contains bovine serum albumin (BSA). Be careful when pipetting to avoid bubbles. If bubbles persist, burst the bubbles using a large gauge needle and read the plate again.</li></ul>

## FREQUENTLY ASKED QUESTIONS

---

- 1. I want to perform a lipolysis time course experiment. How many time points can I complete ?** We do not recommend performing more than 2 time points per assay. For time course experiments, add 250  $\mu$ l assay medium with treatments per well. Remove 100  $\mu$ l for each time point. Complete the assay using an equal volume Glycerol Reagent A.
- 2. I do not have time to perform the assay. Can I freeze the conditioned media? How long can I store the samples before I complete the assay?** Yes. The conditioned media can be immediately stored at -80°C for a maximum of 7 days in regular polystyrene cell culture plates. Bring the conditioned media in the plate to room temperature **BEFORE** adding the Glycerol Reagent A and completing the assay.
- 3. Can I buy the reagents separately?** The Glycerol Standard, cat# LIP-GLYSTAN and Glycerol Reagent A, cat# RGTA-10 (11 ml), RGTA-40 (40 ml) are sold separately. Assay Buffer is not sold separately.
- 4. I need to know the concentration of the BSA in the Assay Buffer?** ZenBio, Inc does not provide the concentrations of the components of our media and buffers. If knowledge of the BSA concentration is critical to your experiment, you may order Assay Buffer **WITHOUT** BSA for no additional charge. Please note it on your order.



## REFERENCES

---

1. Arner P (1996) *Diabetes Rev* 4(4):450-463.
2. Botton LM & Green A. *Diabetes* (1999) 48:1691-1697
3. Brasaemle DL, Dolios G, Shapiro L, Wang R. (2004) *J Biol Chem* 279(45): 46835-42.
4. Cooper DMF, Schlegel W, Lin MC, Rodbell M. (1979) *J Biol Chem* 254(18):8927-8931.
5. Dyck DJ *Can J Appl Physiol* (2000) 25(6):495-523.
6. Kordik CP & Reitz AB. *J Medicinal Chem* (1999) 42(2):181-201.
7. Rieusset J, Chambrier C, Bouzakri K, Dussere E, Auwerx J, Riou J-P, Laville M, Vidal H. *Diabetologia* (2001) 44:544-554.
8. Robidoux J, Martin TL, Collins S. (2004) *Ann Rev Chem* 253: 7570-7578.
9. Scriba D, Aprath-Husmann I, Blum WF, Hauner H. *Eur J Endocrinol* (2000) 143:439-445
10. Snyder PB *Emerging Therapeutic Targets* (1999) 3(4): 587-599.
11. Tansey JT, Sztalryd C, Hlavin EM, Kimmel AR, Londos C. (2004) *IUBMB Life* 56(7): 379-85.

# APPENDIX A: PLATE LAYOUT

---

H	G	F	E	D	C	B	A	
								1
								2
								3
								4
								5
								6
								7
								8
								9
								10
								11
								12

# APPENDIX B: PROCEDURE FLOWCHART

